

REF. 2

o FILE TRANSLATION ALSO ATTACH

EV 907491017

⑩ 日本国特許庁 (JP)

⑪ 実用新案出願公開

⑫ 公開実用新案公報 (U)

昭60-122420

⑬ Int. Cl. 4

識別記号

庁内整理番号

⑭ 公開 昭和60年(1985)8月17日

E 04 C 2/30

F-6730-2E

E 04 B 1/40

M-7228-2E

1/62

7904-2E

E 04 C 2/38

6730-2E

審査請求 未請求 (全頁)

⑮ 考案の名称 板体取付部の構造

⑯ 実 願 昭59-10346

⑰ 出 願 昭59(1984)1月27日

⑱ 考 案 者 空 岡 義 幸 豊中市新千里西町1丁目1番12号 ナショナル住宅産業株式会社内

⑲ 出 願 人 ナショナル住宅産業株式会社 豊中市新千里西町1丁目1番12号

⑳ 代 理 人 弁理士 宮井 暎夫

RECEIVED

SEP 26 2006

JAMES R. CYPHER



[]

明 細 書

1. 考案の名称

板体取付部の構造

2. 実用新案登録請求の範囲

5 取付基体と、板体と、両側片の少なくとも一方
 の対向内面に爪を突設しその両側片で前記板体の
 端部両面を挾持して爪を板体内部へ食い込ませた
 状態で一方の側片外面を前記取付基体に対接した
 コ字形補強材と、この補強材の両側片および前記
 10 板体に貫通して前記取付基体へ固着した固着具と
 を備えた板体取付部の構造。

3. 考案の詳細な説明

〔技術分野〕

15 この考案は、パネル表面板をパネル枠体へ固定
 する場合等に適用できる板体取付部の構造に關す
 るものである。

〔背景技術〕

20 従来の建築用パネルは、第1図に示すように、
 パネル表面板1の裏面端部をパネル外枠材2上に
 載置し、ビス3をパネル表面板1からパネル外枠

(1) RECEIVED

SEP 26 2006

170

JAMES R. CYPHER

材 2 へねじ込んで組立てる。

ところが、パネル表面板 1 をビス 3 のみでパネル外枠材 2 へ固定するため、パネル表面板 1 が面方向の外力 F を受けて第 1 図左方へ引っ張られると、ビス 3 が倒れたり、ビス部分でパネル表面板 1 に亀裂が生じるという問題を有していた。

〔考案の目的〕

この考案の目的は、パネル表面板等の板体が面方向の外力を受けた場合でも、その板体固定用の固着具が倒れたり、その固着具部分で板体に亀裂が入ったりするのを防止できる板体取付部の構造を提供することである。

〔考案の開示〕

この考案の板体取付部の構造は、取付基体と、板本と、両側片の少なくとも一方の対向内面に爪を突設しその両側片で前記板体の端部両面を挟持して爪を板体内部へ食い込ませた状態で一方の側片外面を前記取付基体に対接したコ字形補強材と、この補強材の両側片および前記板体に貫通して前記取付基体へ固着した固着具とを備える。

(2)

RECEIVED

SEP 26 2006 171

JAMES R. CYPHER

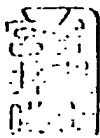

この考案の一実施例を第 2 図に示す。この板体
取付部の構造は、第 2 図に示すように、パネル表
面板 4 を金属製溝形パネル外枠材 5 へ固定するの
に適用したもので、ビス 6 の他に補強金具 7 を使
用する。

この補強金具 7 は、コ字形形状で、その両側片
7 a , 7 b の対向内面端部に爪 7 c を内向に突設
し、その両側片 7 a , 7 b でパネル表面板 4 の両
面端部を挟持して爪 7 c をパネル表面板 4 に食い
込ませた状態で、一方の側片 7 b 外面をパネル外
枠材 5 の上面に対接する。そして、ビス 6 を補強
金具 7 の両側片 7 a , 7 b およびパネル表面板 4
に貫通してパネル外枠材 5 へねじ込むことにより、
パネル表面板 4 をパネル外枠材 5 へ固定する。

このように構成した結果、パネル表面板 4 が面
方向の外力 F を受けても、その荷重をビス 6 のみ
ならず、補強金具 7 の爪 7 c によっても保持でき
るため、外力 F に対する耐荷重強度を従来よりも
向上できて、ビス 6 の倒れや、ビス部分でのパネ
ル表面板 4 のクラック発生を確実に防止できる。

(3)

RECEIVED 172
SEP 26 2006
JAMES R. CYPHER

11 12 13 14 15 16 17 18 19 20

なお、上記実施例においては、爪70を両側片7a, 7bに設けたが、爪70をいずれか一方の側片7aまたは7bのみに設けるようにしてもよい。また、爪70の形成位置も、両側片7a, 7bの対向内面であれば、いずれの場所に設けてもよい。

この考案は、上記のようにパネル表面板4をパネル外枠材5へ連結する場合に適用できることはもちろんのこと、それ以外にも板体を取付基体へ連結する場合に広く適用可能である。

〔考案の効果〕

この考案の板体取付部の構造によれば、板体が面方向の外力を受けた場合でも、固着具が倒れたり、その固着具部分で板体に亀裂が入ったりするのを防止できるという効果が得られる。

4. 図面の簡単な説明

第1図は従来のパネルの断面図、第2図はこの考案の一実施例の斜視図である。

4…パネル表面板(板体)、5…パネル外枠材(取付基体)、6…ビス(固着具)、7…補強金

(4)

RECEIVED 173

SEP 26 2006

JAMES R. CYPHER

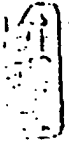

具、7 a、7 b ... 側片、7 o ... 爪

代理人 弁理士 宮 井 暎 夫

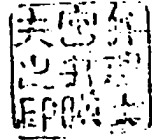

5

10

15

20

(5)

RECEIVED
174
SEP 26 2006
JAMES R. CYPHER

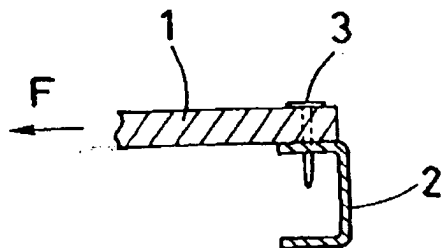

第 1 図

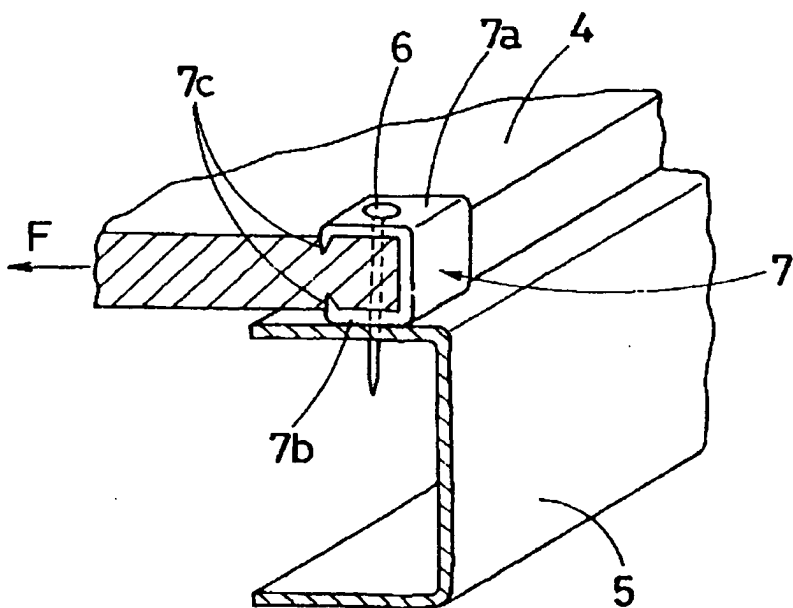

第 2 図

175

RECEIVED
SEP 26 2006
JAMES R. CYPHER

実開60-122420

弁理士 宮井 暎 夫
58-217B1599 1/1

JP-U1-S60-122420

Japanese Utility Model Unexamined Publication No. S60-122420

Date of Publication: August 17, 1985

Application No. S59-10346

Date of Application: January 27, 1984

Inventors: Yoshiyuki Soraoka

Applicant: National Housing Industrial Co., Ltd.

Title of the Invention: STRUCTURE OF PLATE BODY MOUNTING PORTION

Claims:

1. A structure of plate mounting portion comprising a mounting base substance, a plate, a \sqcap -shaped reinforcing member having at least one of both side pieces provided with a claw protruded from at least one of inner surfaces thereof, an outer surface of one side piece contacting with said mounting base substance in a manner of the side pieces clamping both surfaces of an end portion of the plate while the claw bites thereinto, and fasteners passing through the both side pieces and said plate to fasten them to said mounting base substance.

Brief Description of the Drawings:

Fig. 1 is a sectional view of a conventional panel, and Fig. 2 is a perspective view of one embodiment of the present invention.

4 ... a panel surface plate (a plate), 5 ... a panel outer frame member (a mounting base substance), 6 ... a bis (fastener), 7 ... a reinforcing fitting, 7a, 7b ... a side piece, 7c ... a claw.

RECEIVED

SEP 26 2006

JAMES R. CYPHER

Unexamined New Utility Model Digest (U) S60-122420

Publication Date: August 17, 1985

Application No.: S59-10346

Application Date: January 27, 1984

Inventor: Soraoka Yoshiyuki

Applicant: National Housing Industrial Co., Ltd.

Title of Device: Structure of a Plate Attachment

(p.1)

Specification

1. Title of Device

Structure of a plate attachment

2. Claims

The structure of a plate attachment, comprising:

an attachment main body;

a plate;

a reinforcing material shaped as a rectangle with an open side that attaches to said attachment main body the external surface of one side with a claw protruding toward at least one of the opposite interior sides of the two sides, holding the two surfaces of the edges of said plate with the two sides and inserting the claw into the interior of the plate; and

a fastener that passes through both sides of this reinforcing material and through said plate and fastens to said attachment main body.

3. Detailed Description of the Device

[Field of the Device]

This device pertains to the structure of a plate attachment capable of application in instances of fixing a panel surface plate to a panel frame, etc.

[Description of the Prior Art]

Conventional architectural panels, as shown in Fig. 1, are assembled by mounting the rear surface edge of panel external surface plate 1 onto panel external frame material 2 and screwing

(p.2)

screws 3 from panel external surface plate 1 into panel external frame material 2.

However, since panel exterior surface plate 1 is fastened to panel external frame material 2 only by screws 3, if panel exterior surface plate 1 sustains an external force F in the surface

direction and stretches to the left in Fig. 1, screws 3 may break and cracks may form in panel exterior surface plate 1 in the screw areas. These represent problems.

[Object of the Device]

The object of this device is to provide a plate attachment structure capable of keeping attachment devices for fixation of these plates from breaking, and to keep cracks from forming on the plate at these fastener locations, even when the panel exterior surface plate or other plate sustains an external direction [sic] in the surface direction.

[Disclosure of the Device]

The structure of a plate attachment in this device comprises an attachment main body; a plate; a reinforcing material shaped as a rectangle with an open side that attaches to said attachment main body the external surface of one side with a claw protruding toward at least one of the opposite interior sides of the two sides, holding the two surfaces of the edges of said plate with the two sides and inserting the claw into the interior of the plate; and a fastener that passes through both sides of this reinforcing material and through said plate and fastens to said attachment main body.

(p.3)

An embodiment of this device is shown in Fig. 2. This structure of a plate attachment is applied to the fastening of a panel exterior surface plate 4 to a metallic grooved panel exterior frame 5, with a reinforcing clasp 7 used in addition to screws 6, as shown in Fig. 2

This reinforcing clasp 7 has the shape of a rectangle with one open side. A claw 7c is situated protruding toward the interior on the opposite interior surface edges of the two sides 7a and 7b. The external surface of one side 7b is attached to the upper surface of panel exterior frame 5 with the two edges of panel exterior surface plate 4 held by these two sides 7a and 7b and claw 7c inserted into panel exterior surface plate 7. In addition, by screwing screws 6 through both sides 7a and 7b of reinforcing clasp 7 and through panel exterior surface plate 4 into panel exterior frame 5, panel exterior surface plate 4 is fixed to panel external frame 5.

As a consequence of this configuration, even when panel exterior surface plate 4 sustains an external force 7 in the surface direction, it is possible to maintain that load by means not only of screws 6 [but also] of claw 7c of reinforcing clasp 7. Accordingly, it is possible to increase the load-bearing strength against external force F from conventional [levels] and to conclusively prevent breakage of screws 6 and the generation of cracks in panel exterior surface plate 4.

(p.4)

In the embodiment described above, claw 7c is provided on both sides 7a and 7b, but it is acceptable to provide claw 7c on either one side 7a or 7b only. Also, if the forming position is on the opposite interior surface of both sides 7a and 7b, [claw 7c] may be provided in either position.

This device of course can be applied when connecting panel external surface plate 4 to panel exterior frame 5, as described above. However, [this device] can be applied widely in circumstances other than this [in which] a plate is connected to an attachment main body.

[Effect of the Device]

The structure of a plate attachment in this device yields the effect of being able to prevent fasteners from breaking and to prevent cracks from forming in the areas of these fasteners, even when the plate sustains an external force in the surface direction.

4. Brief Description of the Drawings

Fig. 1 is a sectional view of a conventional panel. Fig. 2 is a lateral view of an embodiment of this device.

- 4 Panel exterior surface plate (plate)
- 5 Panel external frame (attachment main body)
- 6 Screws (fasteners)
- 7 Reinforcement clasp

(p.5)

- 7a, 7b Sides
- 7c Claw

Patent Agent: Miyai Teruo

(p.6)

Fig. 1

Fig. 2

Patent Agent: Miyai Teruo